

MITYLITE®

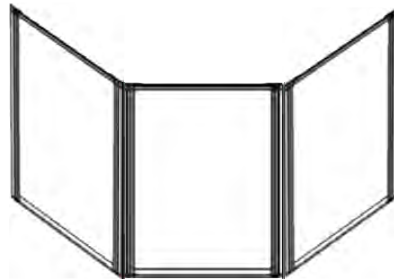

PROTECTION SHIELDS

FRAMED COUNTERTOP SHIELDS

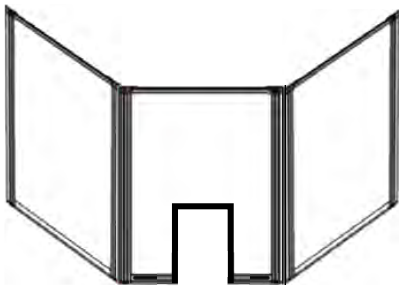

Designed to help employees and customers feel more protected amidst the current crisis, these clear, acrylic partitions provide a shield that prevents direct physical and airborne contact.

Available in four models.

PERFECT FOR:

- *Hospitality*
- *Public Assembly Spaces*
- *Government Offices*
- *Educational Environments*
- *Hospitals/Clinics*
- *Pharmacies*
- *Reception/Front Desk*
- *Banks*
- *Convenience Stores*
- *Grocery Stores*
- *Worship Services*

KEY PRODUCT LINE BENEFITS

- Manufactured in the USA
- Free freight in the Contiguous USA
- Solid aluminum frame with clear acrylic construction
- Easy to clean with wipes, bleach, and common disinfectants
- Practical design features an opening at the bottom or a cutout for the transfer of small items, papers, and payment
- Scan barcodes through the acrylic to prevent physical contact
- Sturdy design weighs 12-24 pounds and is not easily tipped over (use screws or adhesive strips for added stability)

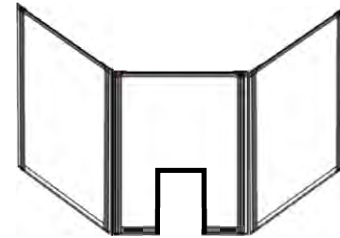

24 lbs

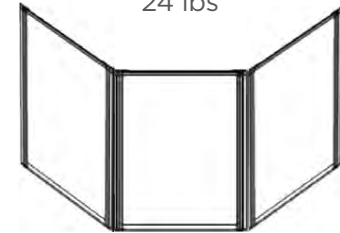

24 lbs



12 lbs



12 lbs



"This screen would make me a lot more comfortable when talking with sick people coming into this clinic. I try to be personal to all customers but I've got to keep my distance from sick people."

-Pharmacist, Minnesota



Warranty Details:
mityinc.com/warranty

mityinc.com

800-909-8034

FRAMED COUNTERTOP SHIELD

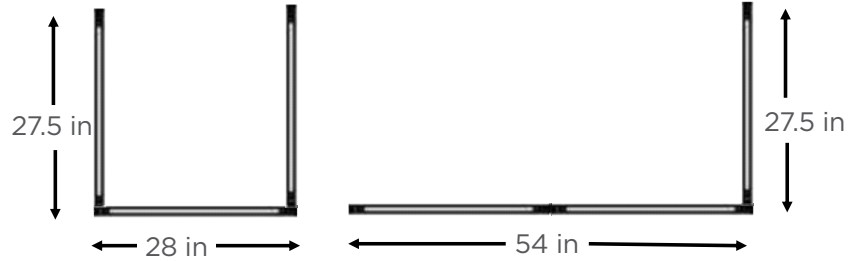
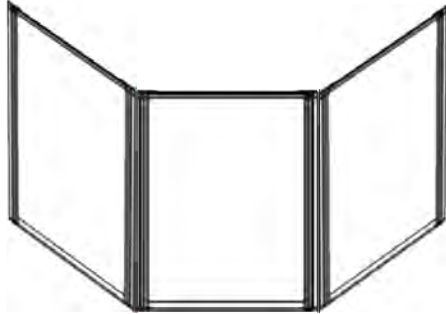

Dimensions represent framed panel sizing.

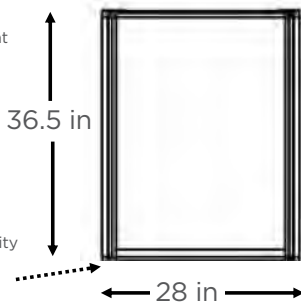

*Total height variability based on foot/hardware used.

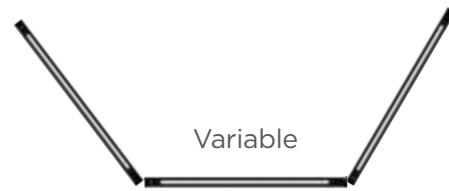

FRAMED COUNTERTOP SHIELD WITH CUTOUT

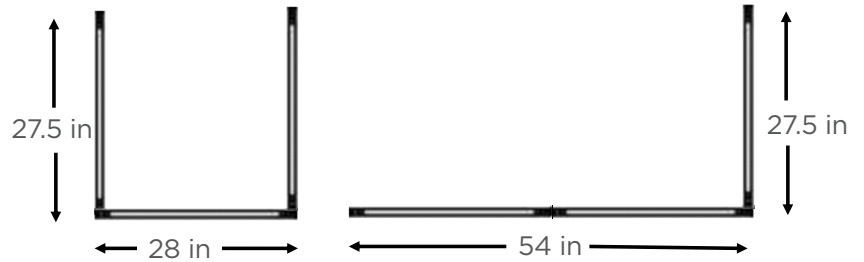
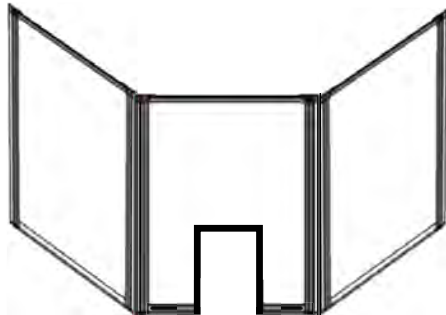

Dimensions represent framed panel sizing.

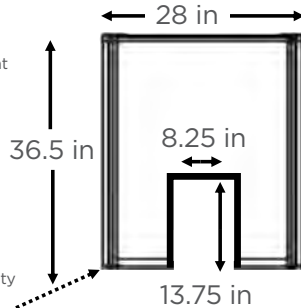

*Total height variability based on foot/hardware used.



FRAMED COUNTERTOP SINGLE SHIELD

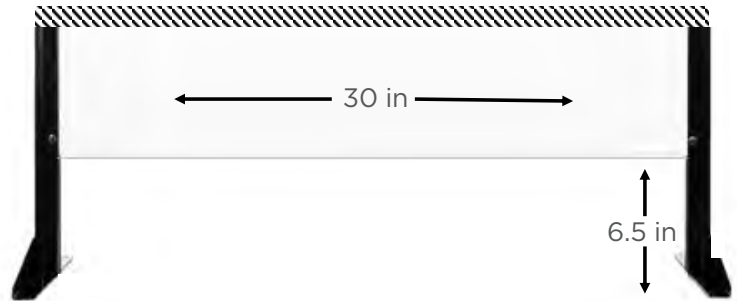
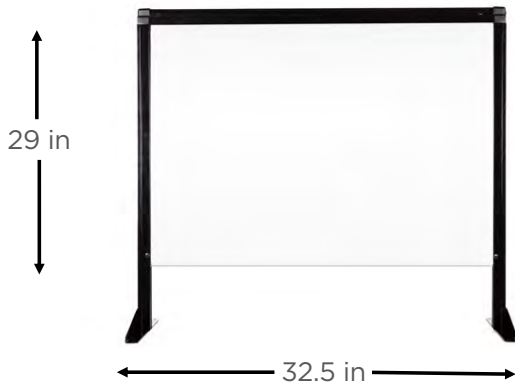

Inside window dimensions

Dimensions represent framed size.

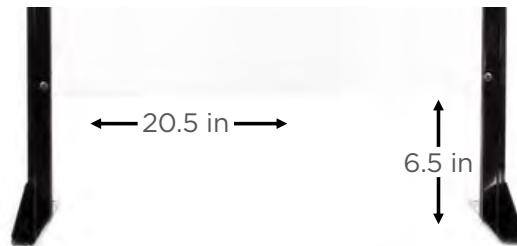
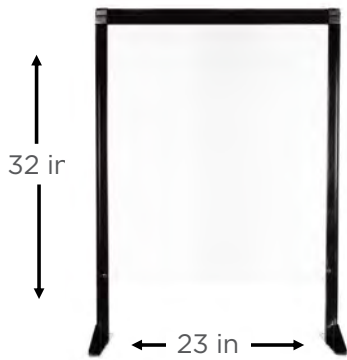

Inside window dimensions

