

SPECIFICATIONS

Applications:

The SwiftSet® Cart – Half Tree is designed to hold 48 SwiftSet® un-upholstered chairs or 36 SwiftSet® upholstered chairs. The chairs stack horizontally on the cart in 6 locations.

Primary Structure:

The cart shall consist of a steel frame, 2 swivel casters, and 2 fixed casters. A handle is provided to steer the cart. The hanging tubes shall be coated with protective, neoprene rubber. Ends of the hanging tubing have a 1.25" plastic plug.

QUICK SPECS			
Width	Height	Length	Weight
31 1/2"	73 1/4"	40"	82 lbs
DIMENSIONS LOADED			
Width	Height	Length	Weight
31 1/2"	74 1/4"	46"	634 lbs

Part	Material Size
Main Frame	1 1/2" x 1 1/2" x 14 gauge (.083) square tubing
Hanging Tubes	1 1/4" x 14 gauge (.083) round tubing
Handle	1 1/4" x 14 gauge (.083) round tubing

Casters:

There shall be 2 front swivel casters and 2 rear fixed casters. They shall be 2" wide x 6" diameter, rounded, soft, thermoplastic elastomer tread, with 1/2" roller bearings. They shall have a load capacity of not less than 450 pounds each.

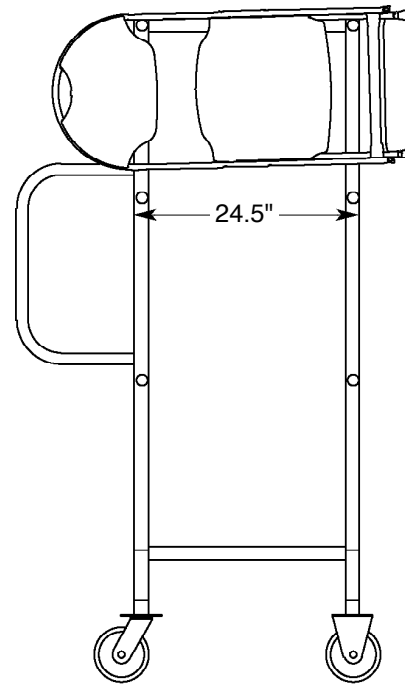
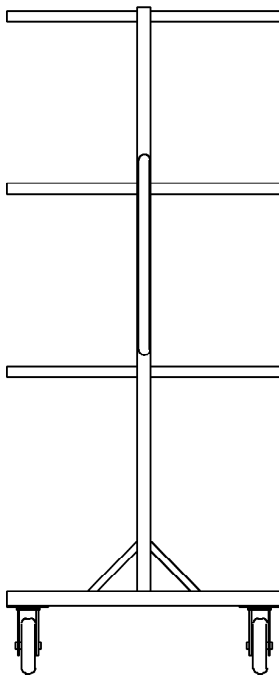

Part number example: CRTCHSSHTBLK2 or CRTCHSSHTBRN2

www.mitylite.com 1.800.327.1692 • 1.801.224.0589 • fax 1.801.224.6191